

Repair Service:

<https://jd-rep.com/english/kontakt.html> Phone: +49 5121 267 359

Chapter 5 • Power Panel 35

1. PP35 types



Short description					
Photo					
Model number	4PP035.0300-01	4PP035.0300-36	4PP035.E300-01	4PP035.E300-36	4PP035.E300-136
Page	102	122	102	122	
LCD display					
160 x 80 pixels	✓				
Character set					
European / Cyrillic	✓		✓		
Keys					
Total	16		26		
With key LED	12		10		
With insert strips	10		10		
Inputs / outputs					
Digital inputs	16	8	16	8	
Digital outputs	16	8	16	8	
Analog inputs	-	4	-	4	
Analog outputs	-	4	-	4	
FlashPROM					
1,0 MB	✓				-
1,9 MB	-				✓

Table 40: PP35 overview

2. Power Panel 35-01

2.1 Photos

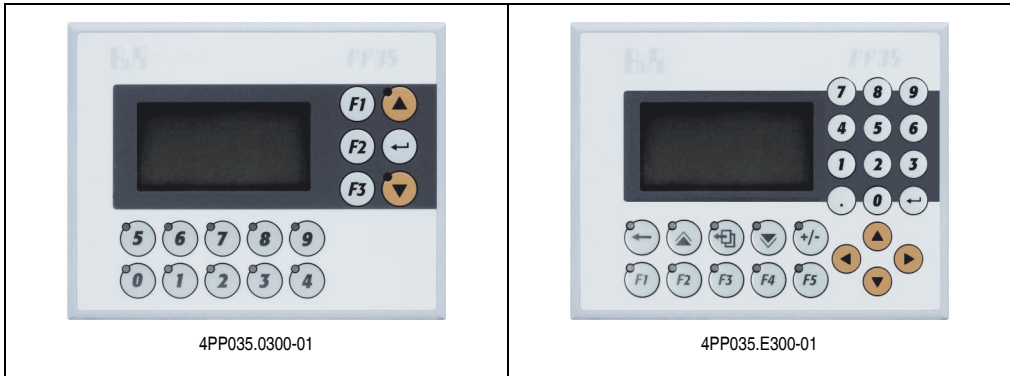

Figure 56: PP35-01 photos

2.2 Order data

Model number	Short description
4PP035.0300-01	Power Panel, 24 VDC, 153 x 120 mm, LC display, 160x80 Pixel, 3", background lighting, European / Cyrillic character set, 16 keys, 300 KB SRAM, 1024 kB FlashPROM, 1 RS232, 1 CAN interface, 16 digital inputs, 24 VDC, sink / source, 2 event counters, 1 incremental encoder or 2 gate-/period measurement, 16 digital outputs, 24 VDC, 0.5 A source, IP65 protection (from front). 2 x TB718 and 1 x TB103 terminal blocks sold separately.
4PP035.E300-01	Power Panel, 24 VDC, 153 x 120 mm, LC display, 160x80 Pixel, 3", background lighting, European / Cyrillic character set, 26 keys, 300 KB SRAM, 1024 kB FlashPROM, 1 RS232, 1 CAN interface, 16 digital inputs, 24 VDC, sink / source, 2 event counters, 1 incremental encoder or 2 gate-/period measurement, 16 digital outputs, 24 VDC, 0.5 A source, IP65 protection (from front). 2 x TB718 and 1 x TB103 terminal blocks sold separately.
Note	
All parts required to install the Power Panel, including key legend sheets, are included in its delivery.	
Required accessories	
0TB103.9	Accessory terminal block, 3-pin, Screw clamp, 2.5 mm ² ; protected against vibration by the screw flange.
0TB103.91	Accessory terminal block, 3-pin, Cage clamps, 2.5 mm ² ; protected against vibration by the screw flange.
7TB718.9	Accessory terminal block, 18-pin, screw clamp, 1.5 mm ²
7TB718.91	Accessory terminal block, 18-pin, cage clamp, 1.5 mm ²

Table 41: PP35-01 order data

Model number	Short description
Optional accessories	
0AC201.9 ¹⁾	Lithium batteries, 5 pcs., 3 V / 950 mAh, button cell
4A0006.00-000 ¹⁾	Lithium battery, 3 V / 950 mAh, button cell
4A0044.00-000	5 DIN A4 legend strips, 6 fields for a total of 30 devices
7AC911.9	Bus connector, CAN

Table 41: PP35-01 order data (Forts.)

1) Replacement part

2.3 Technical data

Product ID	PP35-01
General information	
Certification	CE, C-UL-US, GOST-R
Standards Temperature Shock / tests carried out Vibration / tests carried out Emission / tests carried out Immunity / tests carried out	IEC61131-2 / IEC60068-2-x IEC61131-2 / IEC60068-2-27 IEC61131-2 / IEC60068-2-6 EN61000-6-4 / EN55022 IEC 61131-2 / IEC 61000-4-x
Status display	I/O function for each channel, status
Diagnostics Status I/O function Interfaces	Yes, with status LED Yes, with LEDs Yes, with LEDs
Display	
Type	LCD b/w
Resolution	160 x 80 pixels
Background lighting	LED
Character set	European / Cyrillic
Keys	
Total keys 4PP035.0300-01 4PP035.E300-01	16 (12 with LEDs) 26 (10 with LEDs)
System keys	Number block Control keys
Labeling	10 keys with insert strips

Table 42: PP35-01 technical data

Power Panel 35-01 • Technical data

Product ID	PP35-01
Processor	
Typical instruction cycle time	0.8 μ s, average value at 70% bit and 30% analog processing
Standard memory User RAM System PROM User PROM 4PP035.0300-01 4PP035.E300-01	300 kB SRAM 448 kB FlashPROM 1024 kByte FlashPROM 1024 kByte FlashPROM
Data buffering with backup battery	Lithium battery, 3 V / 950 mAh
Battery buffer current	Max. 60 μ A
Hardware Watchdog	Yes
Voltage monitoring	An NMI is triggered at a supply voltage of <15 VDC.
Real-time clock	1 s resolution, nonvolatile memory
System bus for expansions	No
Operating system	PP01x (version V 2.36 and higher)
Status display / diagnostics	
Status LED	Red / green
RS232 LED	Indicates if data is being transmitted or received
CAN LED	Indicates if data is being transmitted or received
I/O LED	Displays whether LEDs 1-16 indicate an input or output state.
01-16 LEDs	State of inputs and outputs
Interfaces	
Application interface IF1 Type Design Electrical isolation Max. transfer rate Distance	RS232 9-pin DSUB plug No 115.2 kbit/s 15 m / 19,200 bit/s
Application interface IF2 Type Design Electrical isolation Distance Max. transfer rate Bus length 60 m Bus length 200 m Bus length 1,000 m	CAN bus 9-pin DSUB plug Yes max. 1,000 m bus length 500 kbit/s 250 kbit/s 50 kbit/s

Table 42: PP35-01 technical data (Forts.)

Product ID	PP35-01	
Digital inputs		
Channels	1-3	4-16
Additional functions for inputs	2 x event counter or 1 x incremental encoder ABR/AB or 2 x gate/period measurement	-
Input circuit	Sink or source	Sink or source
Input voltage (nom./max.)	24 VDC / 30 VDC	24 VDC / 30 VDC
Input current at nominal voltage	ca. 10 mA	ca. 5 mA
Switching threshold LOW HIGH	<5 V >15 V	
Input filter	<10 µs	<1 ms
Electrical isolation Channel - bus Channel - channel Group isolation	Yes No No	Yes No No
Event counter operation		
Amount	2	
Counter 1/2	Input 1 / 2	
Counter size	32-bit	
Input frequency	Max. 50 kHz	
Signal form	Square wave pulse	
Evaluation	Positive or negative edge, cyclic counter	
Incremental encoder operation		
Amount	1	
Type	ABR or AB	
Counter size	32-bit	
Input frequency	Max. 20 kHz	
Evaluation	4x	
Signal form	Square wave pulse	

Table 42: PP35-01 technical data (Forts.)

Power Panel 35-01 • Technical data

Product ID	PP35-01
Gate measurement	
Number of gate measurements	2
Gate measurement on channel 1 and 2 Channel 1 Channel 2	Input 1 Input 2
Counter size	32-bit
Evaluation	Positive or negative edge
Input frequency	Max. 50 kHz
Pulse length	$\geq 10 \mu\text{s}$
Length of pauses between pulses	$\geq 10 \mu\text{s}$
Count frequency Internal External	4 MHz, 31.25 kHz Max. 50 kHz
Signal form	Square wave pulse
Period measurement	
Number of period measurements	2
Measurement on channel 1 and 2 Channel 1 Channel 2	Input 1 Input 2
Counter size	32-bit
Evaluation	Positive or negative edge
Input frequency	Max. 50 kHz
Count frequency Internal External	4 MHz, 31.25 kHz Max. 50 kHz
Signal form	Square wave pulse

Table 42: PP35-01 technical data (Forts.)

Product ID	PP35-01
Digital outputs	
Channels	16
Type	Highside driver (source)
Switching voltage	
Minimum	18 VDC
Nominal	24 VDC
Maximum	30 VDC
Nom. output current	0.5 A
Total current	8 A
Output circuit	Source
Max. switching frequency	100 Hz
Switching delay	max. 500 µs
Short-circuit protection	Yes
Overload protection	Yes
Internal protective circuit	VDR
Electrical isolation	
Channel - bus	No
Channel - channel	No
Group isolation	No
Power supply	
Supply voltage	
Minimum	18 VDC
Nominal	24 VDC
Maximum	30 VDC
Power consumption	Max. 6 W
Environmental conditions	
Temperature	
Operation	0°C to 50°C
Storage	-20°C to 60°C
Humidity	
Operation	10 to 90% (non-condensing)
Storage	5 to 95% (non-condensing)
Mechanics	
Protection	IP65 (from front)
Outer dimensions (B x H x T [mm])	153 x 120 x 46.1
Weight	0.5 kg

Table 42: PP35-01 technical data (Forts.)

2.4 Diagnostic LEDs

Multiple LEDs on the back of the device show the status of the Power Panel, the interfaces, and the digital I/O:

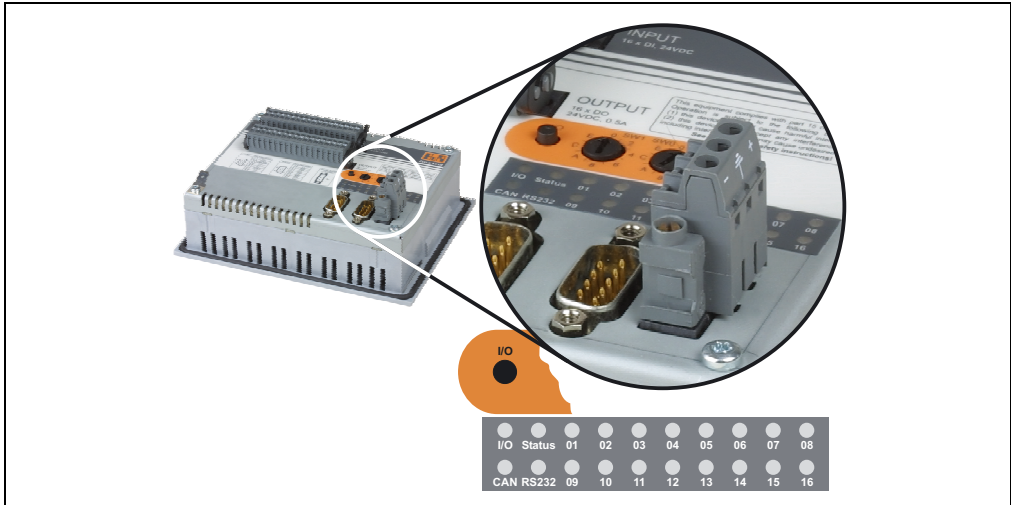

Figure 57: PP35-01 diagnostic LEDs

2.4.1 Status LED

The Power Panel status LED uses a blink code to indicate the operating state of the Power Panel:

Power Panel operating state	Color/blink code of the status LED	
Boot mode	Blinking yellow / green 1 Hz	
Flash programming	Blinking green / red 5 Hz	
Service mode / Diagnostic mode	Yellow	
Run	Green	
Error	Red	

Table 43: PP35-01 status LED

2.4.2 I/O LEDs

The I/O LED indicates whether the I/O LEDs (01 ... 16) show the state of the digital inputs or outputs. The display can be set appropriately using the I/O button.

I/O LED	LEDs 01 ... 16
Green	The state of the 16 digital inputs is indicated (LEDs are green).
Yellow	The state of the 16 digital outputs is indicated (LEDs are yellow).

Table 44: PP35-01 I/O LEDs

2.4.3 Interface LEDs

Interface LED	Description
CAN	Indicates if data is being transmitted or received.
RS232	Indicates if data is being transmitted or received.

Table 45: PP35-01 interface LEDs

2.5 Digital inputs

2.5.1 Terminal block connections

Inputs 1 - 3 are equipped with additional functions (event counter, ABR evaluation, etc.). The supply voltage for the digital inputs can be monitored with the application program.

18-pin terminal block	Terminal	Assignment
 <p>X1</p> <p>7TB718.91</p>	1	COM si (GND in sink operation, 24 VDC in source operation)
	2	COM so (24 VDC in sink operation, GND in source operation)
	3	Input 1 / counter 1 / A
	4	Input 2 / counter 2 / B
	5	Input 3 / ext. CLK / R
	6	Input 4
	7	Input 5
	8	Input 6
	9	Input 7
	10	Input 8
	11	Input 9
	12	Input 10
	13	Input 11
	14	Input 12
	15	Input 13
	16	Input 14
	17	Input 15
	18	Input 16

Table 46: PP35-01 terminal assignments X1 / digital inputs

2.5.2 Connection examples

Sink connection

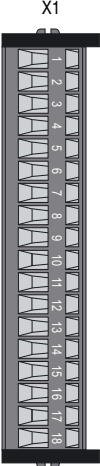
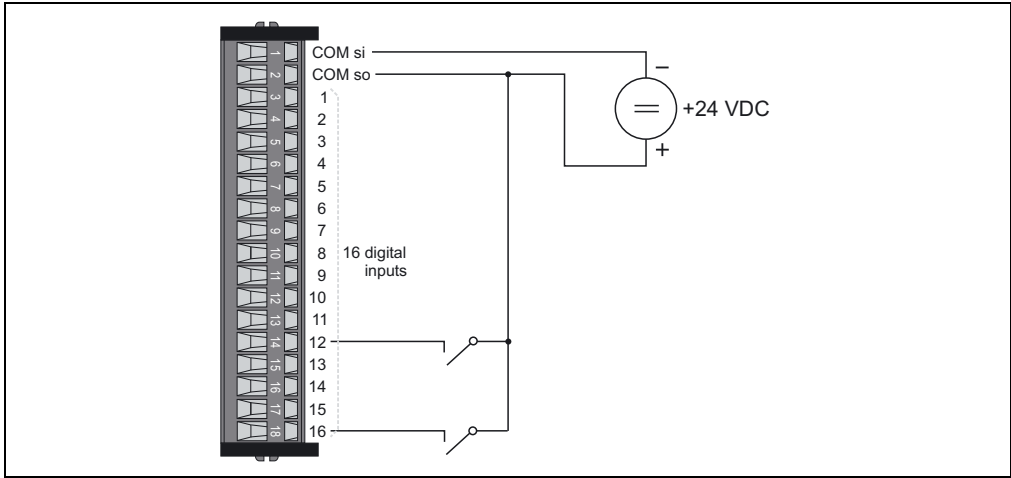

Figure 58: PP35-01 digital input connection examples (sink connection)

Source connection

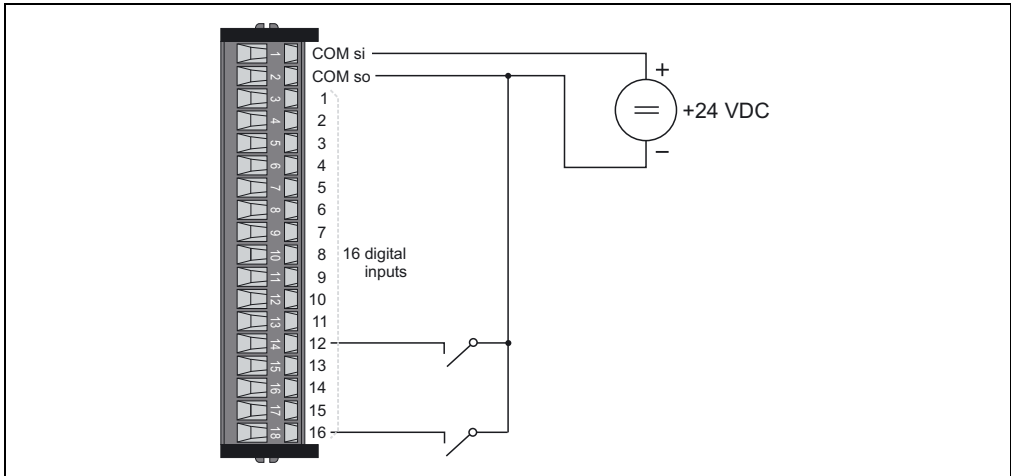

Figure 59: PP35-01 digital input connection examples (source connection)

Counter inputs

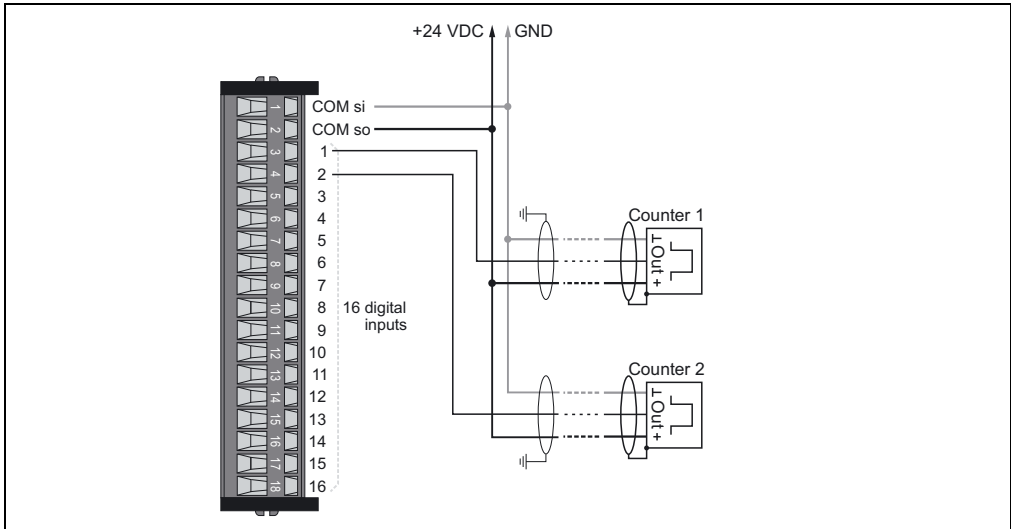

Figure 60: PP35-01 connection example - counter input

Period or gate measurement

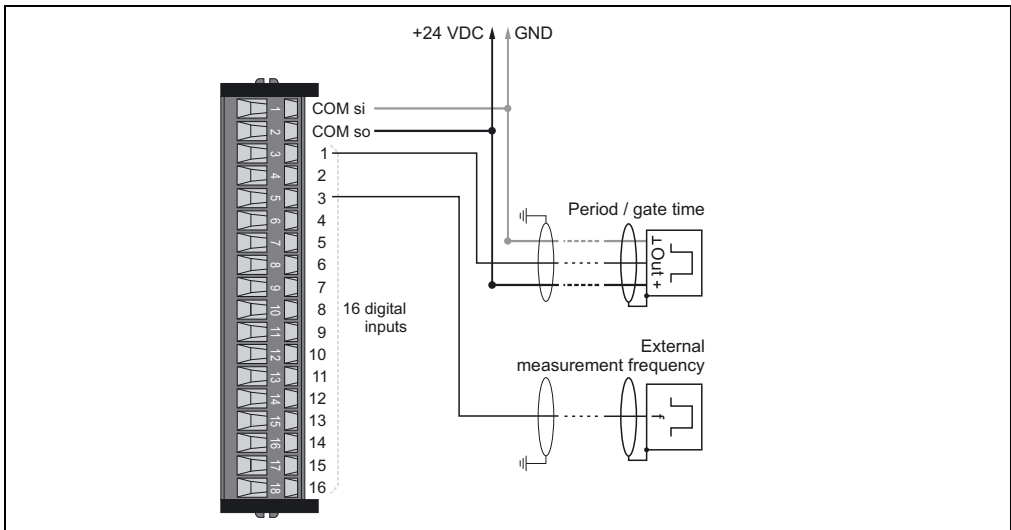

Figure 61: PP35-01 connection example - period and gate measurement

Incremental encoders

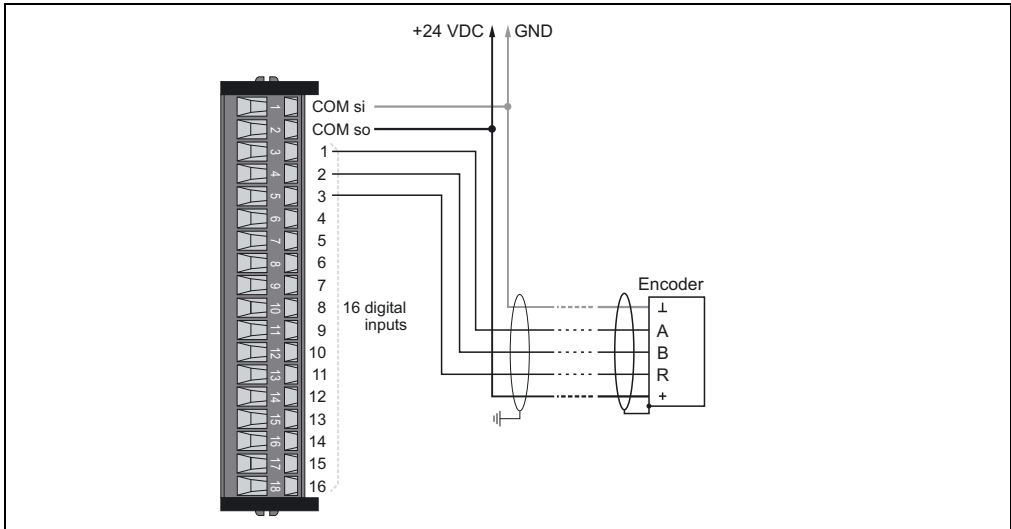

Figure 62: PP35-01 connection example - incremental encoder

2.5.3 Input circuit diagram

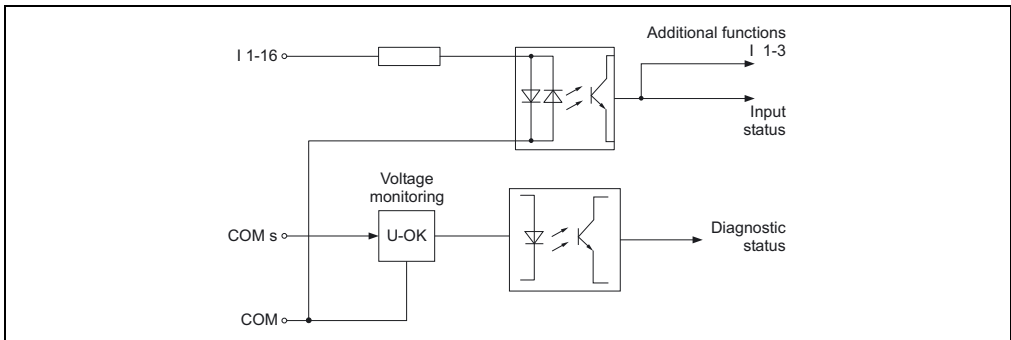

Figure 63: PP35-01 input circuit diagram - digital inputs

2.6 Digital outputs

2.6.1 Terminal block connections

18-pin terminal block	Terminal	Assignment
 <p>X2</p> <p>7TB718.91</p>	1	GND
	2	24 VDC (DO supply)
	3	Output 1
	4	Output 2
	5	Output 3
	6	Output 4
	7	Output 5
	8	Output 6
	9	Output 7
	10	Output 8
	11	Output 9
	12	Output 10
	13	Output 11
	14	Output 12
	15	Output 13
	16	Output 14
	17	Output 15
	18	Output 16

Table 47: PP35-01 terminal assignment - X2 / digital outputs

2.6.2 Connection example

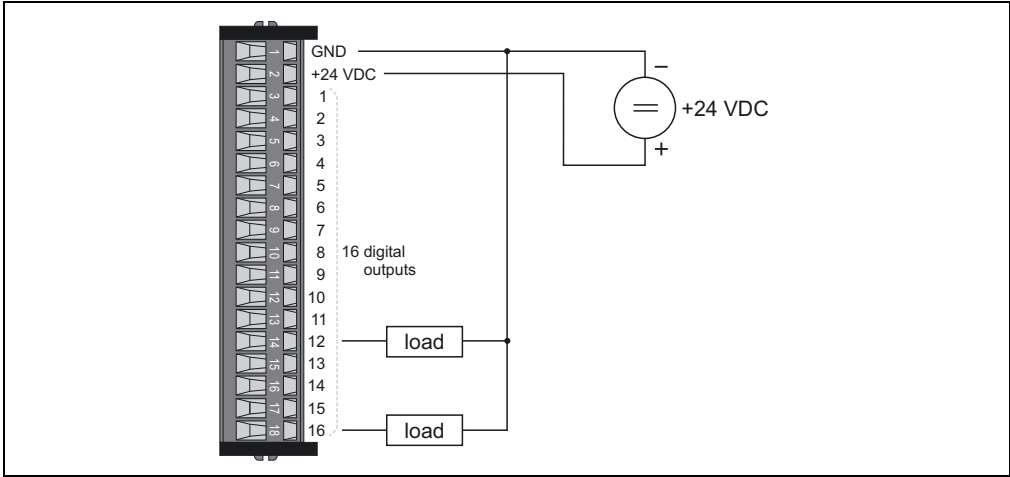

Figure 64: PP35-01 connection example - digital outputs

2.6.3 Output circuit diagram

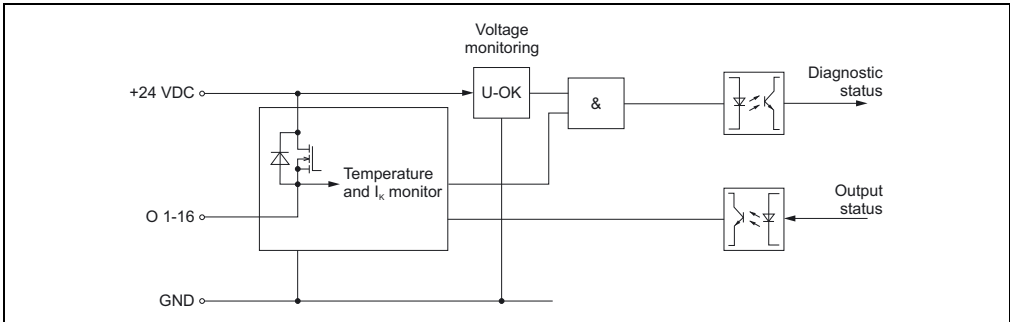

Figure 65: PP35-01 output circuit diagram - digital outputs

2.7 Variable declaration

Description	Name in Automation Studio	Data type	Description
Digital in 1 - 16	Digital input 01 - 16	BIT	Level of digital inputs 1 - 16
Digital out 1 - 16	Digital output 01 - 16	BIT	Level of digital outputs 1 - 16
Counter 1	Analog input 01	UDINT	Counter state 1 (bit 1 - bit 32)
Counter 2	Analog input 02	UDINT	Counter state 2 (bit 1 - bit 32)
DO back	Analog input 03	UINT	Actual state of the digital outputs 1 - 16
Status	Analog input 04	UINT	Status word
Config	Analog output 01	UINT	Configuration word

Table 48: PP35-01 variable declaration

2.7.1 Configuration register



Bit	Description
0	Reserved
1	This setting applies only in AB(R) mode (bit 4+5 set to 01): 0 ... R disabled 1 ... R enabled
2	Switch between period and gate measurement (only evaluated if bits 4+5 are set to 11): 0 ... Period measurement 1 ... Gate measurement
3	Beginning of period or gate measurement: 0 ... at rising (positive) edge 1 ... at falling (negative) edge
5-4	00 ... no counter operation 01 ... AB(R) counter 10 ... Event counter 11 ... Period or gate measurement
7-6	00 ... Counter frequency 4 MHz 01 ... External counter frequency 10 ... Counter frequency 31.25 kHz 11 ... Not allowed
8	0 ... At the reference impulse (positive edge) counter 1 is copied to counter 2 1 ... At the reference impulse (positive edge) counter 1 is reset to counter 0
9	Overrun recognition by counter 1 (only applies in period duration / gate time mode; see bit 4-5 and bit 2 of the configuration register): 0 ... Shut off overrun recognition and reset overrun bit of counter 1 (bit 9 in the status register). 1 ... Overrun recognition of the continuous counter. The counter value is limited to \$0000FFFF.
10	Overrun recognition by counter 2 (only applies in period duration / gate time mode; see bit 4-5 and bit 2 of the configuration register): 0 ... Shut off overrun recognition and reset overrun bit of counter 2 (bit 10 in the status register). 1 ... Overrun recognition of the continuous counter. The counter value is limited to \$0000FFFF.
14-11	Reserved
15	0 ... Reset time or counter 1 ... Enable time or counter (set this bit to 1 after counter has been configured)

The reserve bits can only be written with the value 0.

2.7.2 Status register



Bit	Description
8-0	Reserved
9	Information regarding counter 1 at period or gate measurement (only applies when bit 9 is set in the configuration register): 0 ... The counter's value is within the range 0 - \$0000FFFF. 1 ... counter overrun! Acknowledge by resetting bit 9 of the configuration register.
10	Information regarding counter 2 at period or gate measurement (only applies when bit 10 is set in the configuration register): 0 ... The counter's value is within the range 0 - \$0000FFFF. 1 ... counter overrun! Acknowledge by resetting bit 10 of the configuration register.
11	Reserved
12	Monitoring of the 24 VDC input supply 0 ... Input supply OK 1 ... Error: input supply to low or missing
14-13	Reserved
15	Monitoring of the 24 VDC output supply 0 ... Output supply OK 1 ... Error: output supply to low or missing

2.7.3 DO back (status of digital outputs)

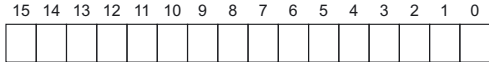

Bit	Description
0	0 ... Actual state of digital output 1: OUT 1 ... Actual state of digital output 1: IN
1	0 ... Actual state of digital output 2: OUT 1 ... Actual state of digital output 2: IN
2	0 ... Actual state of digital output 3: OUT 1 ... Actual state of digital output 3: IN
3	0 ... Actual state of digital output 4: OUT 1 ... Actual state of digital output 4: IN
4	0 ... Actual state of digital output 5: OUT 1 ... Actual state of digital output 5: IN
5	0 ... Actual state of digital output 6: OUT 1 ... Actual state of digital output 6: IN
6	0 ... Actual state of digital output 7: OUT 1 ... Actual state of digital output 7: IN
7	0 ... Actual state of digital output 8: OUT 1 ... Actual state of digital output 8: IN
8	0 ... Actual state of digital output 9: OUT 1 ... Actual state of digital output 9: IN
9	0 ... Actual state of digital output 10: OUT 1 ... Actual state of digital output 10: IN
10	0 ... Actual state of digital output 11: OUT 1 ... Actual state of digital output 11: IN
11	0 ... Actual state of digital output 12: OUT 1 ... Actual state of digital output 12: IN
12	0 ... Actual state of digital output 13: OUT 1 ... Actual state of digital output 13: IN
13	0 ... Actual state of digital output 14: OUT 1 ... Actual state of digital output 14: IN
14	0 ... Actual state of digital output 15: OUT 1 ... Actual state of digital output 15: IN
15	0 ... Actual state of digital output 16: OUT 1 ... Actual state of digital output 16: IN

2.7.4 Counter settings

To set the correct counter modes, the configuration register must be written. Counter 1 and counter 2 registers have different meanings for different modes.

Incremental encoder operation

If the homing input (input 3) is *enabled* in the configuration register, then the Power Panel is a 32-bit ABR counter whose actual value is found in counter 1 and the saved R value in counter 2.

If the homing input is disabled, a 32-bit AB incremental encoder counter input is read in counter 1.

- A = digital input 1
- B = digital input 2
- R = digital input 3

Event counter operation

If the counters in the configuration register are initialized as event counters, two 32-bit counters are available.

- Counter 1 = digital input 1
- Counter 2 = digital input 2

Period measurement

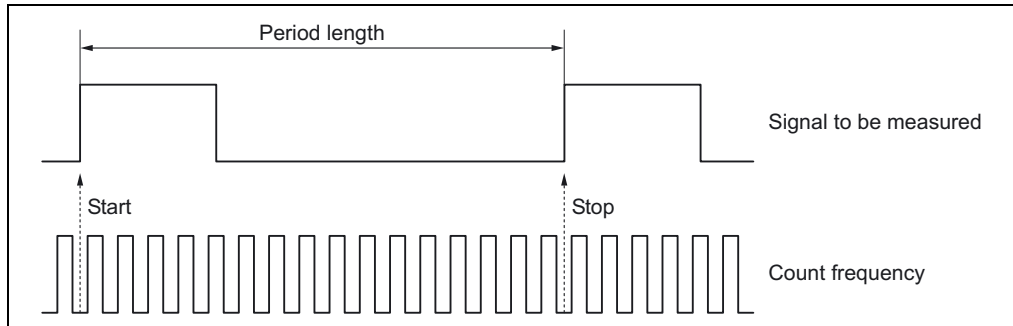

Figure 66: PP35-01 period measurement

The measurement can be begin at the decreasing or increasing edge depending on the configuration register. The counter frequency can be set in two steps (4 MHz or 31.25 kHz) or with an external frequency. The external frequency must however be less than 50 kHz. The measured counter state is a 32-bit value and is displayed in counter 1 or counter 2. The value in the temporary register is only updated at the end of the measurement.

The frequency of the signal to be measured can be a maximum of 50 kHz.

- Counter 1 = digital input 1
- Counter 2 = digital input 2
- Ext. Counting frequency = digital input 3

A potential overrun of the continuous counter during the period measurement (e.g. due to an incorrect counter frequency), can be detected by reading bit 9 (counter 1) or bit 10 (counter 10) in the status register. However, the maximum value of counter is limited to \$0000FFFF as a result. The error bit in the status register is acknowledged by resetting bit 9 (counter 1) or bit 10 (counter 2) of the configuration register.

Gate measurement

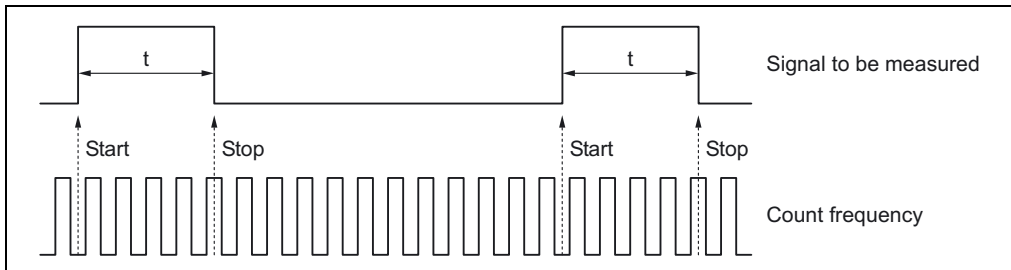

Figure 67: PP35-01 gate measurement

The measurement can be begin at the decreasing or increasing edge depending on the configuration register. The R enable bit must be 0. Measurement always occurs up to the next edge. The counter frequency can be set to one of two levels (4 MHz or 31.25 kHz) or with an external frequency. The external frequency must however be less than 50 kHz. The measured counter state is a 32-bit value and is displayed in counter 1 or counter 2. The value in the temporary register is only updated at the end of the active measurement.

The frequency of the signal to be measured can be a maximum of 50 kHz.

- Counter 1 = digital input 1
- Counter 2 = digital input 2
- Ext. Counting frequency = digital input 3

A potential overrun of the continuous counter during the gate measurement (e.g. due to an incorrect counter frequency), can be detected by reading bit 9 (counter 1) or bit 10 (counter 2) in the status register. However, the maximum value of counter is limited to \$0000FFFF as a result. The error bit in the status register is acknowledged by resetting bit 9 or bit 10 of the configuration register.

3. Power Panel 35-36

3.1 Photos

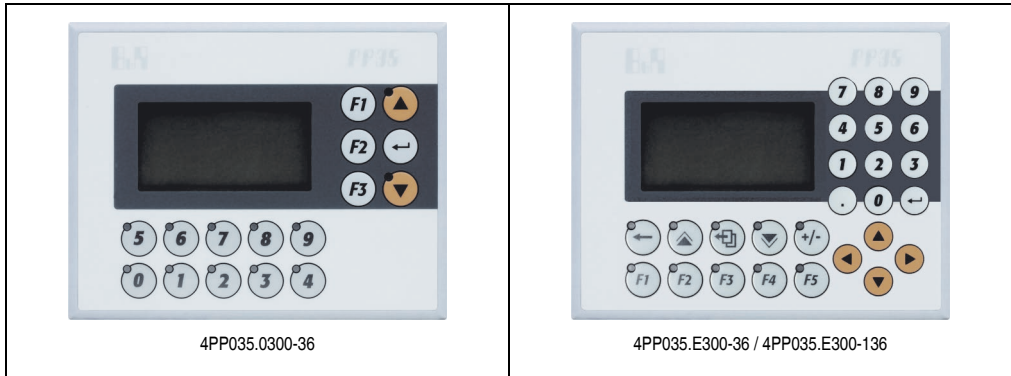

Figure 68: Power Panel 35-36 photos

3.2 Order data

Model number	Short description
4PP035.0300-36	Power Panel, 24 VDC, 153 x 120 mm, LC display, 160x80 pixels, 3", background lighting, European / Cyrillic character set, 16 keys, 300 kB SRAM, 1024 kB FlashPROM, 1 RS232, 1 CAN interface, 8 digital inputs, 24 VDC, sink / source, 2 event counters, 1 incremental encoder or 2 gate-/period measurement, 8 digital outputs, 24 VDC, 0.5 A source, 4 analog inputs, ± 10 V, 12-bit, two of the analog inputs can be used as KTY10 or PT1000 inputs. 4 analog outputs, ± 10 V, 12-bit, IP65 protection (from front). 2 x TB718 and 1 x TB103 terminal blocks sold separately.
4PP035.E300-36	Power Panel, 24 VDC, 153 x 120 mm, LC display, 160x80 pixels, 3", background lighting, European / Cyrillic character set, 26 keys, 300 kB SRAM, 1024 kB FlashPROM, 1 RS232, 1 CAN interface, 8 digital inputs, 24 VDC, sink / source, 2 event counters, 1 incremental encoder or 2 gate-/period measurement, 8 digital outputs, 24 VDC, 0.5 A source, 4 analog inputs, ± 10 V, 12-bit, two of the analog inputs can be used as KTY10 or PT1000 inputs. 4 analog outputs, ± 10 V, 12-bit, IP65 protection (from front). 2 x TB718 and 1 x TB103 terminal blocks sold separately.
4PP035.E300-136	Power Panel, 24 VDC, 153 x 120 mm, LC display, 160x80 pixels, 3", background lighting, European / Cyrillic character set, 26 keys, 300 kB SRAM, 1984 kB FlashPROM, 1 RS232, 1 CAN interface, 8 digital inputs, 24 VDC, sink / source, 2 event counters, 1 incremental encoder or 2 gate-/period measurement, 8 digital outputs, 24 VDC, 0.5 A source, 4 analog inputs, ± 10 V, 12-bit, two of the analog inputs can be used as KTY10 or PT1000 inputs. 4 analog outputs, ± 10 V, 12-bit, IP65 protection (from front). 2 x TB718 and 1 x TB103 terminal blocks sold separately.
Note	
All parts required to install the Power Panel, including key legend sheets, are included in its delivery.	
Required accessories	
0TB103.9	Accessory terminal block, 3-pin, Screw clamp, 2.5 mm ² ; protected against vibration by the screw flange.
0TB103.91	Accessory terminal block, 3-pin, Cage clamps, 2.5 mm ² ; protected against vibration by the screw flange.
7TB718.9	Accessory terminal block, 18-pin, screw clamp, 1.5 mm ²
7TB718.91	Accessory terminal block, 18-pin, cage clamp, 1.5 mm ²

Table 49: Power Panel 35-36 order data

Model number	Short description
Optional accessories	
0AC201.9 ¹⁾	Lithium batteries, 5 pcs., 3 V / 950 mAh, button cell
4A0006.00-000 ¹⁾	Lithium battery, 3 V / 950 mAh, button cell
4A0044.00-000	5 DIN A4 legend strips, 6 fields for a total of 30 devices
7AC911.9	Bus connector, CAN

Table 49: Power Panel 35-36 order data (Forts.)

1) Replacement part

3.3 Technical data

Product ID	Power Panel 35-36
General information	
Certification	CE, C-UL-US, GOST-R
Standards Temperature Shock / tests carried out Vibration / tests carried out Emission / tests carried out Immunity / tests carried out	IEC61131-2 / IEC60068-2-x IEC61131-2 / IEC60068-2-27 IEC61131-2 / IEC60068-2-6 EN61000-6-4 / EN55022 IEC 61131-2 / IEC 61000-4-x
Status display	I/O function for each channel, status
Diagnostics Status I/O function Interfaces	Yes, with status LED Yes, with LEDs Yes, with LEDs
Display	
Type	LCD b/w
Resolution	160 x 80 pixels
Background lighting	LED
Character set	European / Cyrillic
Keys	
Total keys 4PP035.0300-36 4PP035.E300-36 4PP035.E300-136	16 (12 with LEDs) 26 (10 with LEDs) 26 (10 with LEDs)
System keys	Number block Control keys
Labeling	10 keys with insert strips

Table 50: Power Panel 35-36 technical data

Power Panel 35-36 • Technical data

Product ID	Power Panel 35-36
Processor	
Typical instruction cycle time	0.8 µs, average value at 70% bit and 30% analog processing
Standard memory User RAM System PROM User PROM 4PP035.0300-36 4PP035.E300-36 4PP035.E300-136	300 kB SRAM 448 kB FlashPROM 1024 kByte FlashPROM 1024 kByte FlashPROM 1984 kByte FlashPROM
Data buffering with backup battery	Lithium battery, 3 V / 950 mAh
Battery buffer current	Max. 30 µA
Hardware Watchdog	Yes
Voltage monitoring	An NMI is triggered at a supply voltage of <15 VDC.
Real-time clock	1 s resolution, nonvolatile memory
System bus for expansions	No
Operating system	PP01x (version V 2.36 and higher)
Status display / diagnostics	
Status LED	Red / green
RS232 LED	Indicates if data is being transmitted or received
CAN LED	Indicates if data is being transmitted or received
I/O LED	Displays whether LEDs 1-16 indicate an input or output state.
01-16 LEDs	State of inputs and outputs
Interfaces	
Application interface IF1 Type Design Electrical isolation Max. transfer rate Distance	RS232 9-pin DSUB plug No 115.2 kbit/s 15 m / 19,200 bit/s
Application interface IF2 Type Design Electrical isolation Distance Max. transfer rate Bus length 60 m Bus length 200 m Bus length 1,000 m	CAN bus 9-pin DSUB plug Yes max. 1,000 m bus length 500 kbit/s 250 kbit/s 50 kbit/s

Table 50: Power Panel 35-36 technical data (Forts.)

Product ID	Power Panel 35-36	
Digital inputs		
Channels	1-3	4-8
Additional functions for inputs	2 x event counter or 1 x incremental encoder ABR/AB or 2 x gate/period measurement	-
Input circuit	Sink or source	Sink or source
Input voltage (nom./max.)	24 VDC / 30 VDC	24 VDC / 30 VDC
Input current at nominal voltage	ca. 10 mA	ca. 5 mA
Switching threshold LOW HIGH	<5 V >15 V	
Input filter	<10 µs	<1 ms
Electrical isolation Channel - bus Channel - channel Group isolation	Yes No No	Yes No No
Event counter operation		
Amount	2	
Counter 1/2	Input 1 / 2	
Counter size	32-bit	
Input frequency	Max. 50 kHz	
Signal form	Square wave pulse	
Evaluation	Positive or negative edge, cyclic counter	
Incremental encoder operation		
Amount	1	
Type	ABR or AB	
Counter size	32-bit	
Input frequency	Max. 20 kHz	
Evaluation	4x	
Signal form	Square wave pulse	

Table 50: Power Panel 35-36 technical data (Forts.)

Power Panel 35-36 • Technical data

Product ID	Power Panel 35-36
Gate measurement	
Number of gate measurements	2
Gate measurement on channel 1 and 2 Channel 1 Channel 2	Input 1 Input 2
Counter size	32-bit
Evaluation	Positive or negative edge
Input frequency	Max. 50 kHz
Pulse length	$\geq 10 \mu\text{s}$
Length of pauses between pulses	$\geq 10 \mu\text{s}$
Count frequency Internal External	4 MHz, 31.25 kHz Max. 50 kHz
Signal form	Square wave pulse
Period measurement	
Number of period measurements	2
Measurement on channel 1 and 2 Channel 1 Channel 2	Input 1 Input 2
Counter size	32-bit
Evaluation	Positive or negative edge
Input frequency	Max. 50 kHz
Count frequency Internal External	4 MHz, 31.25 kHz Max. 50 kHz
Signal form	Square wave pulse

Table 50: Power Panel 35-36 technical data (Forts.)

Product ID	Power Panel 35-36
Digital outputs	
Channels	8
Type	Highside driver (source)
Switching voltage	
Minimum	18 VDC
Nominal	24 VDC
Maximum	30 VDC
Nom. output current	0.5 A
Total current	4 A
Output circuit	Source
Max. switching frequency	100 Hz
Switching delay	max. 500 µs
Short-circuit protection	Yes
Overload protection	Yes
Internal protective circuit	VDR
Electrical isolation	
Channel - bus	No
Channel - channel	No
Group isolation	No
Analog inputs	
Number of channels	4 differential inputs; 2 of which can be configured individually as temperature inputs
Input	±10 V
Value range / input signal	
10 V	\$7FFF
0 V	\$0000
-10 V	\$8001
Digital converter resolution	12-bit
Conversion time	150 µs for all channels
Input filter	
Hardware	Cut-off frequency 10 kHz / attenuation 60 dB
Software	-
Output format	INT
Input impedance in signal range	20 MΩ
Input circuit	IEC 61131-2
Electrical isolation	
Channel - Power Panel	Yes
Channel - channel	No
Group isolation	No

Table 50: Power Panel 35-36 technical data (Forts.)

Power Panel 35-36 • Technical data

Product ID	Power Panel 35-36
Temperature measurement	
Number of channels	Up to 2 (depending on the configuration)
Input	Resistance measurement using 2-line procedure with constant current measurement
Digital converter resolution	12-bit
Conversion time	150 μ s for all channels
Input filter Hardware Software	Cut-off frequency 10 kHz / attenuation 60 dB -
Output format	INT
Data format	16-bit 2s-complement (INT 16); 1 LSB = 0.1°C
Conversion of measurement values to temperature values	Automatic in the module
Sensor KTY10-6 PT1000	Can be set per channel -50°C to 125°C -200°C to 850°C
Resolution in °C KTY10-6 PT1000	0.13°C 0.56°C
Wiring	2-line
Measuring current	1 mA
Resistance measurement range	0 - 4000 Ω
Input circuit	IEC 61131-2
Electrical isolation	like analog inputs
Analog outputs	
Number of channels	4
Output	\pm 10 V
Value range / output signal 10 V 0 V -10 V	\$7FFF \$0000 \$8001
Max. load per output	\pm 10 mA (load 1 k Ω)
Digital converter resolution	12-bit
Conversion time	150 μ s for all channels
Switch on / switch off procedure	Internal enable relay for boot procedure and error
Basic accuracy	\pm 0.088% at 25°C based on the current output value
Output protection	Continuous short circuit protection
Electrical isolation Channel - bus Channel - channel Group isolation	Yes No No

Table 50: Power Panel 35-36 technical data (Forts.)

Product ID	Power Panel 35-36
Power supply	
Supply voltage	
Minimum	18 VDC
Nominal	24 VDC
Maximum	30 VDC
Power consumption	Max. 6 W
Environmental conditions	
Temperature	
Operation	0°C to 50°C
Storage	-20°C to 60°C
Humidity	
Operation	10 to 90% (non-condensing)
Storage	5 to 95% (non-condensing)
Mechanics	
Protection	IP65 (from front)
Outer dimensions (B x H x T [mm])	153 x 120 x 46.1
Weight	0.5 kg

Table 50: Power Panel 35-36 technical data (Forts.)

3.4 Diagnostic LEDs

Multiple LEDs on the back of the device show the status of the Power Panel, the interfaces, and the digital I/O:

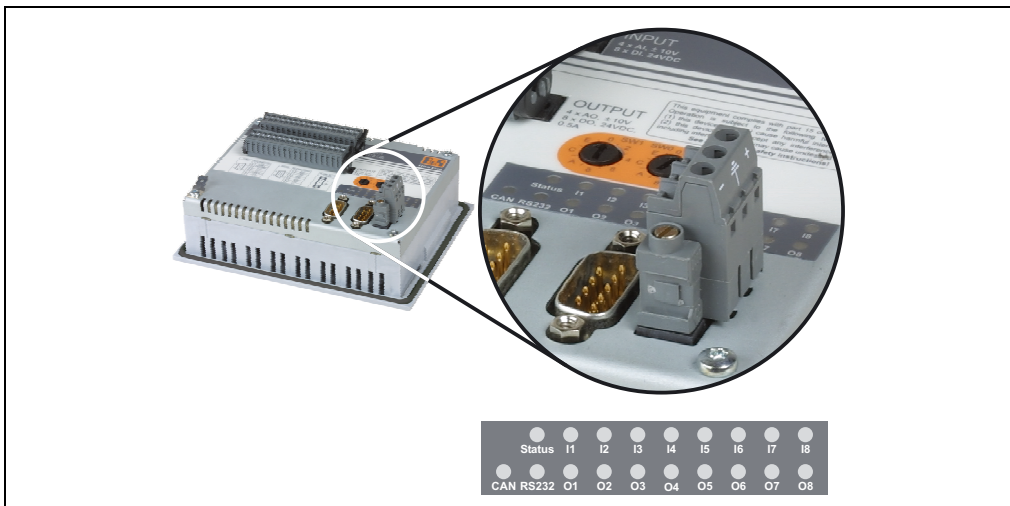

Figure 69: Power Panel 35-36 diagnostic LEDs

3.4.1 Status LED

The Power Panel status LED uses a blink code to indicate the operating state of the Power Panel:





Power Panel operating state	Color/blink code of the status LED	
Boot mode	Blinking yellow / green 1 Hz	
Flash programming	Blinking green / red 5 Hz	
Service mode / Diagnostic mode	Yellow	
Run	Green	
Error	Red	

Table 51: Power Panel 35-36 status LED

3.4.2 I/O LEDs

I/O LED	Description
I1 ... I8	State of the 8 digital inputs
O1 ... O8	State of the 8 digital outputs

Table 52: Power Panel 35-36 I/O LEDs

3.4.3 Interface LEDs

Interface LED	Description
CAN	Indicates if data is being transmitted or received.
RS232	Indicates if data is being transmitted or received.

Table 53: Power Panel 35-36 interface LEDs

3.5 Analog / digital inputs

3.5.1 Terminal block connections

Digital inputs 1 - 3 are equipped with additional functions (event counter, ABR evaluation, etc.). The supply voltage for the digital inputs can be monitored with the application program.

18-pin terminal block	Terminal	Assignment
 <p>X1</p> <p>7TB718.91</p>	1	COM si (GND in sink operation, 24 VDC in source operation)
	2	COM so (24 VDC in sink operation, GND in source operation)
	3	+ Analog input 1
	4	- Analog input 1
	5	+ Analog input 2
	6	- Analog input 2
	7	+ Analog input 3
	8	- Analog input 3
	9	+ Analog input 4
	10	- Analog input 4
	11	Digital input 1 / counter 1 / A
	12	Digital input 2 / counter 2 / B
	13	Digital input 3 / ext. CLK / R
	14	Digital input 4
	15	Digital input 5
	16	Digital input 6
	17	Digital input 7
	18	Digital input 8

Table 54: Power Panel 35-36 terminal assignments - X1 / digital/analog inputs

3.5.2 Connection examples

Analog inputs

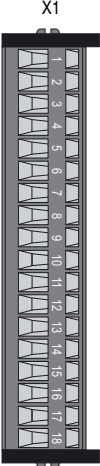
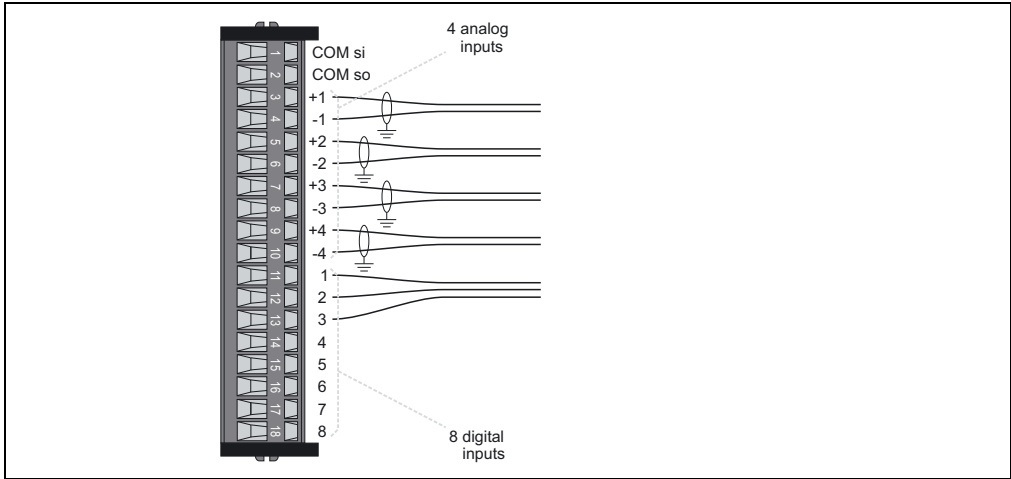

Figure 70: Power Panel 35-36 connection example - analog inputs

Digital inputs (sink connection)

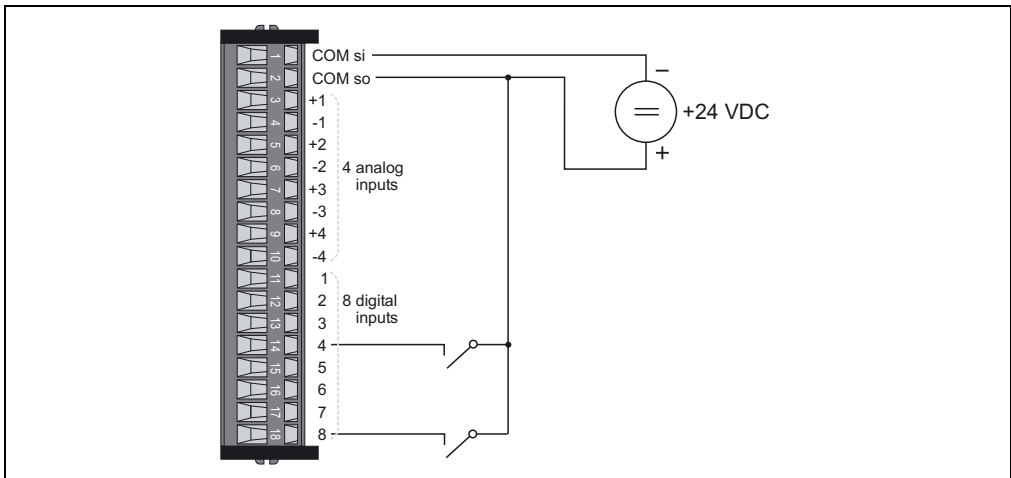

Figure 71: Power Panel 35-36 digital input connection examples (sink connection)

Digital inputs (source connection)

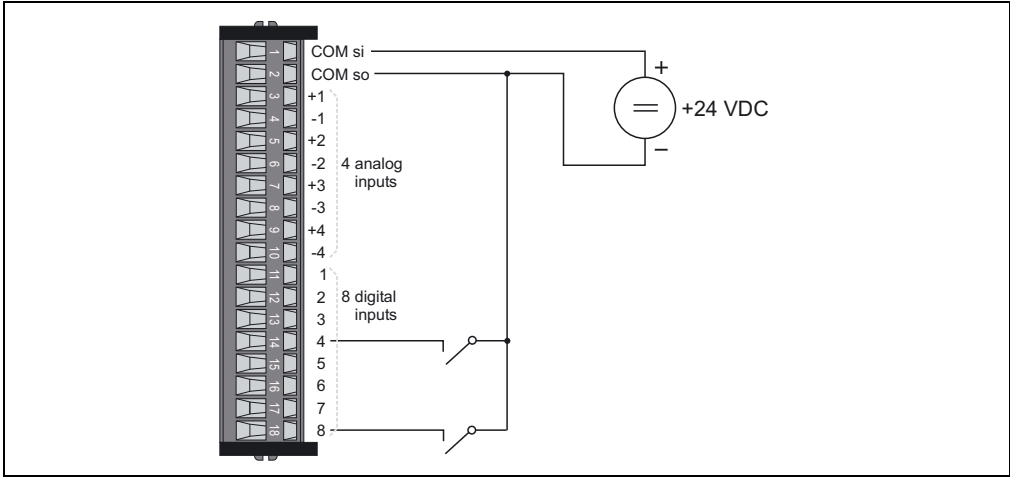

Figure 72: Power Panel 35-36 digital input connection examples (source connection)

Counter inputs

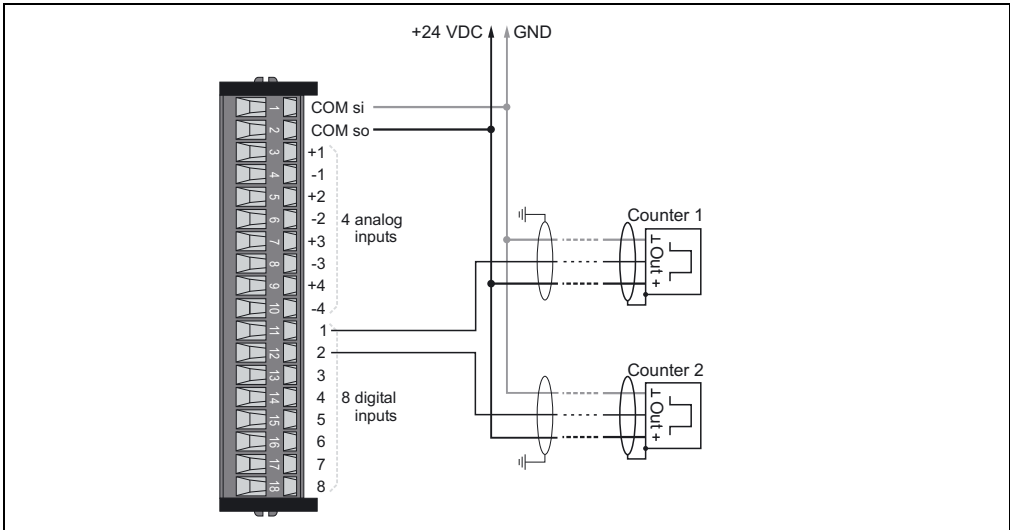

Figure 73: Power Panel 35-36 connection example - counter input

Period or gate measurement

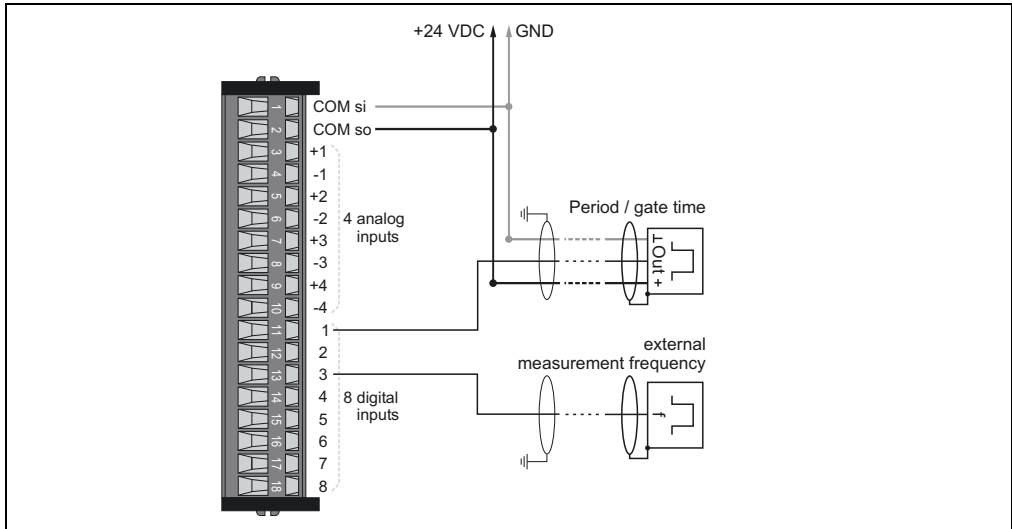

Figure 74: Power Panel 35-36 connection example - period and gate measurement

Incremental encoders

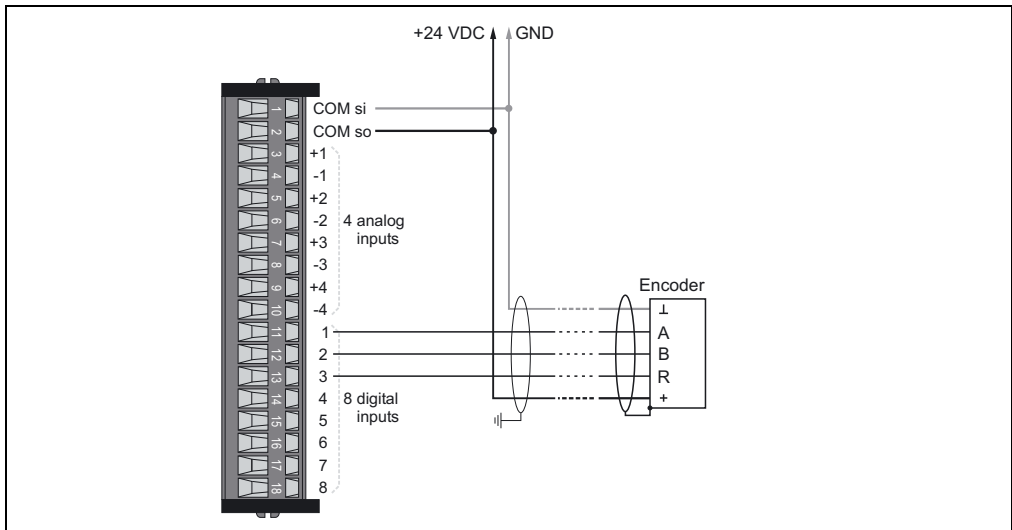

Figure 75: Power Panel 35-36 connection example - incremental encoder

3.5.3 Input circuit diagram

Analog inputs 1 + 2

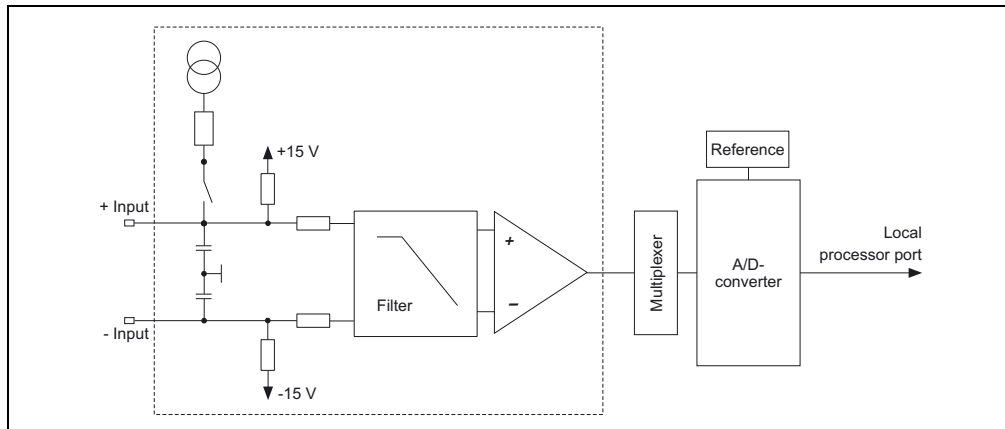

Figure 76: Power Panel 35-36 input circuit diagram - analog inputs 1 + 2

Analog inputs 3 + 4

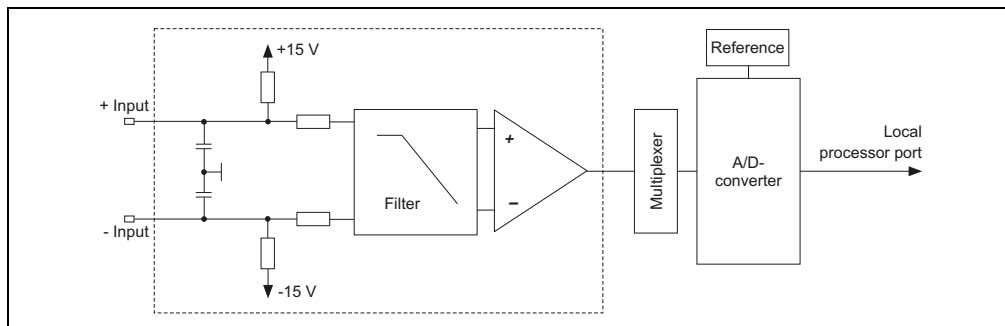

Figure 77: Power Panel 35-36 input circuit diagram - analog inputs 3 + 4

Digital inputs

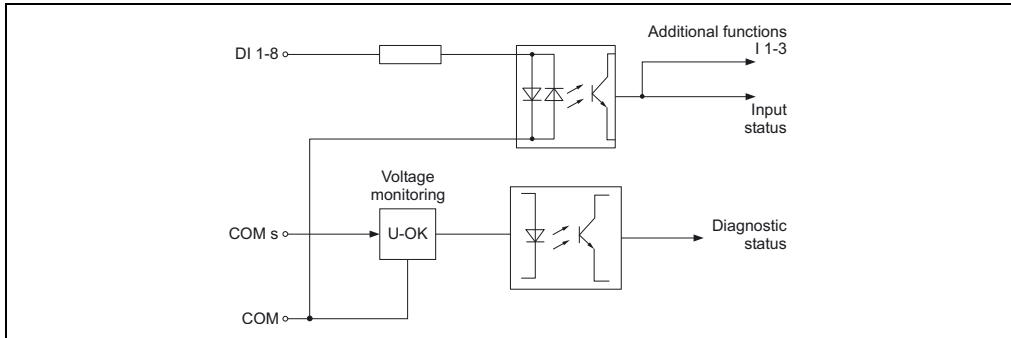

Figure 78: Power Panel 35-36 input circuit diagram - digital inputs

3.6 Analog / digital outputs

3.6.1 Terminal block connections

18-pin terminal block	Terminal	Assignment
<p>7TB718.91</p>	1	GND
	2	24 VDC (DO supply)
	3	+ Analog output 1
	4	⊥ Analog output 1
	5	+ Analog output 2
	6	⊥ Analog output 2
	7	+ Analog output 3
	8	⊥ Analog output 3
	9	+ Analog output 4
	10	⊥ Analog output 4
	11	Digital output 1
	12	Digital output 2
	13	Digital output 3
	14	Digital output 4
	15	Digital output 5
	16	Digital output 6
	17	Digital output 7
	18	Digital output 8

Table 55: Power Panel 35-36 terminal assignment - X2 / digital/analog outputs

3.6.2 Connection examples

Analog outputs

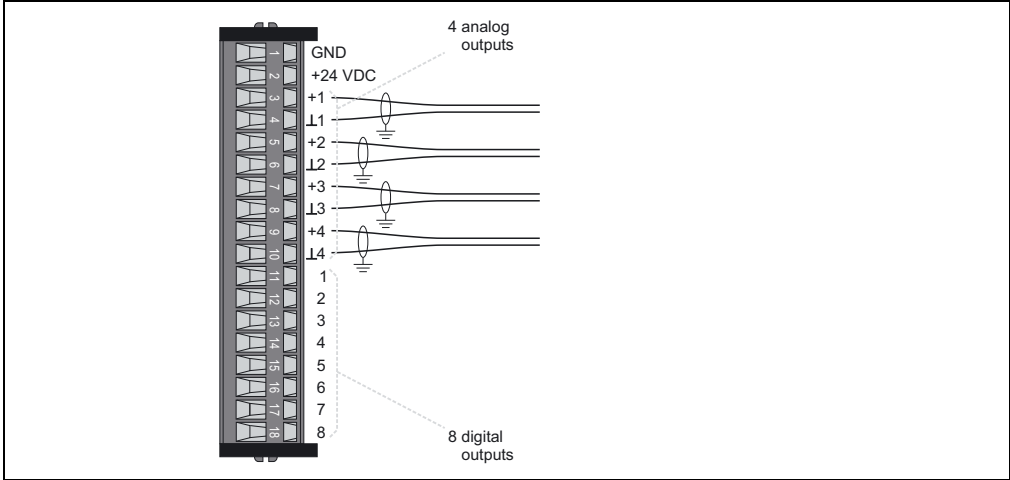

Figure 79: Power Panel 35-36 connection example - analog output

Digital outputs

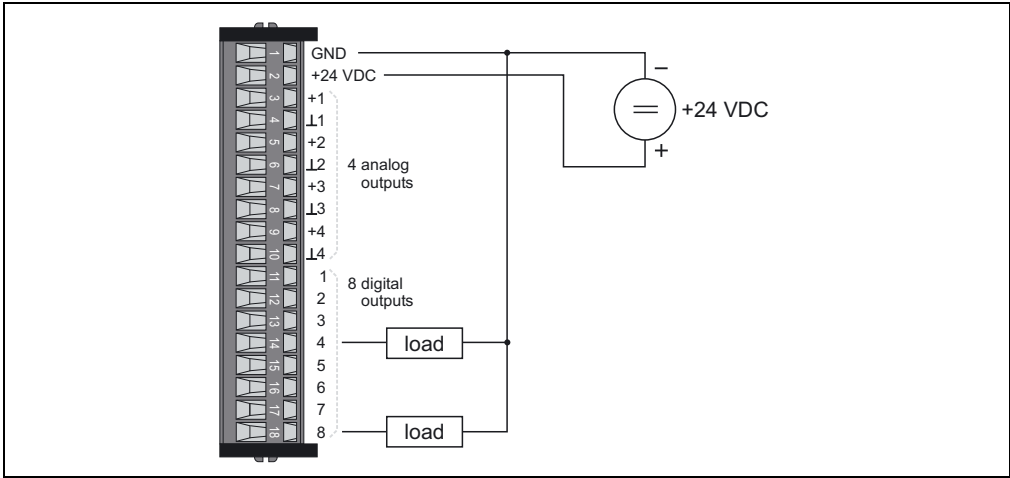

Figure 80: Power Panel 35-36 connection example - digital output

3.6.3 Output circuit diagram

Analog outputs

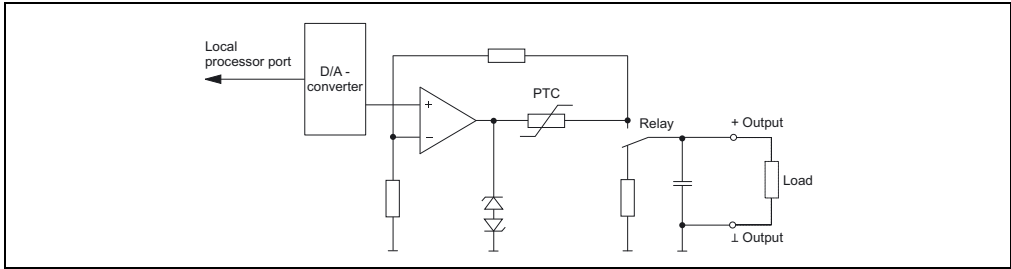

Figure 81: Power Panel 35-36 output circuit diagram - analog outputs

Digital outputs

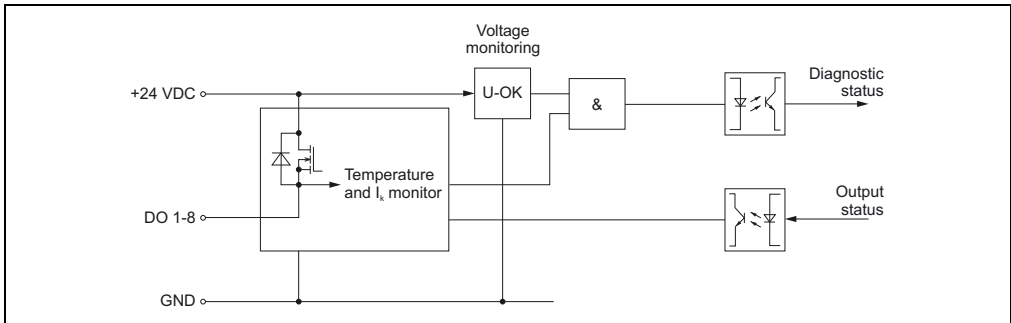

Figure 82: Power Panel 35-36 output circuit diagram - digital outputs

3.7 Variable declaration

Description	Name in Automation Studio	Data type	Description
Digital in 1 - 8	Digital input 01 - 08	BIT	Level of digital inputs 1 - 8
Digital out 1 - 8	Digital output 01 - 08	BIT	Level of digital outputs 1 - 8
Counter 1	Analog input 01	UDINT	Counter state 1 (bit 1 - bit 32)
Counter 2	Analog input 02	UDINT	Counter state 2 (bit 1 - bit 32)
DO back	Analog input 03	UINT	Actual state of the digital outputs 1 - 8
Status	Analog input 04	UINT	Status word
Config	Analog output 01	UINT	Configuration word
Analog in 1	Analog input 05	INT	Analog input 1 (± 10 V, temperature)
Analog in 2	Analog input 06	INT	Analog input 2 (± 10 V, temperature)
Analog in 3	Analog input 07	INT	Analog input 3 (± 10 V)
Analog in 4	Analog input 08	INT	Analog input 4 (± 10 V)
Analog out 1	Analog output 02	INT	Analog output 1 (± 10 V)
Analog out 2	Analog output 03	INT	Analog output 2 (± 10 V)
Analog out 3	Analog output 04	INT	Analog output 3 (± 10 V)
Analog out 4	Analog output 05	INT	Analog output 4 (± 10 V)

Table 56: Power Panel 35-36 variable declaration

3.7.1 Configuration register



Bit	Description
0	Reserved
1	This setting applies only in AB(R) mode (bit 4+5 set to 01): 0 ... R disabled 1 ... R enabled
2	Switch between period and gate measurement (only evaluated if bits 4+5 are set to 11): 0 ... Period measurement 1 ... Gate measurement
3	Beginning of period or gate measurement: 0 ... at rising (positive) edge 1 ... at falling (negative) edge
5-4	00 ... no counter operation 01 ... AB(R) counter 10 ... Event counter 11 ... Period or gate measurement
7-6	00 ... Counter frequency 4 MHz 01 ... External counter frequency 10 ... Counter frequency 31.25 kHz 11 ... Not allowed
8	0 ... At the reference impulse (positive edge) counter 1 is copied to counter 2 1 ... At the reference impulse (positive edge) counter 1 is reset to counter 0
9	Overrun recognition by counter 1 (only applies in period duration / gate time mode; see bit 4-5 and bit 2 of the configuration register): 0 ... Shut off overrun recognition and reset overrun bit of counter 1 (bit 9 in the status register). 1 ... Overrun recognition of the continuous counter. The counter value is limited to \$0000FFFF.
10	Overrun recognition by counter 2 (only applies in period duration / gate time mode; see bit 4-5 and bit 2 of the configuration register): 0 ... Shut off overrun recognition and reset overrun bit of counter 2 (bit 10 in the status register). 1 ... Overrun recognition of the continuous counter. The counter value is limited to \$0000FFFF.
12-11	Analog input 1: 00 ... Voltage measurement (default setting) 01 ... Temperature measurement - PT1000 10 ... Temperature measurement - KTY10-6 11 ... Resistance measurement 1 - 4000 Ω
14-13	Analog input 2: 00 ... Voltage measurement (default setting) 01 ... Temperature measurement - PT1000 10 ... Temperature measurement - KTY10-6 11 ... Resistance measurement 1 - 4000 Ω
15	0 ... Reset time or counter 1 ... Enable time or counter (set this bit to 1 after counter has been configured)

The reserve bits can only be written with the value 0.

3.7.2 Status register



Bit	Description
3-0	Reserved
4	0 ... Analog input 1 - OK 1 ... Analog input 1 - error
5	0 ... Analog input 2 - OK 1 ... Analog input 2 - error
6	0 ... Analog input 3 - OK 1 ... Analog input 3 - error
7	0 ... Analog input 4 - OK 1 ... Analog input 4 - error
8	Reserved
9	Information regarding counter 1 at period or gate measurement (only applies when bit 9 is set in the configuration register): 0 ... The counter's value is within the range 0 - \$0000FFFF. 1 ... Counter overrun! Acknowledge by resetting bit 9 of the configuration register.
10	Information regarding counter 2 at period or gate measurement (only applies when bit 10 is set in the configuration register): 0 ... The counter's value is within the range 0 - \$0000FFFF. 1 ... Counter overrun! Acknowledge by resetting bit 10 of the configuration register.
11	Reserved
12	Monitoring of the 24 VDC input supply 0 ... Input supply OK 1 ... Error: input supply to low or missing
14-13	Reserved
15	Monitoring of the 24 VDC output supply 0 ... Output supply OK 1 ... Error: output supply to low or missing

3.7.3 DO back (status of digital outputs)



Bit	Description
0	0 ... Actual state of digital output 1: OUT 1 ... Actual state of digital output 1: IN
1	0 ... Actual state of digital output 2: OUT 1 ... Actual state of digital output 2: IN
2	0 ... Actual state of digital output 3: OUT 1 ... Actual state of digital output 3: IN
3	0 ... Actual state of digital output 4: OUT 1 ... Actual state of digital output 4: IN
4	0 ... Actual state of digital output 5: OUT 1 ... Actual state of digital output 5: IN
5	0 ... Actual state of digital output 6: OUT 1 ... Actual state of digital output 6: IN
6	0 ... Actual state of digital output 7: OUT 1 ... Actual state of digital output 7: IN
7	0 ... Actual state of digital output 8: OUT 1 ... Actual state of digital output 8: IN
8-15	Reserved

3.7.4 Analog input

The analog inputs deliver data in 16-bit 2s complement (INT16 format). Analog inputs 1 and 2 can be used for voltage, temperature, or resistance measurement by writing to the configuration register.

Depending on these settings, the input data can be interpreted as follows:

Input type	1 LSB means ...	error appears in status register if ...
Voltage measurement	2.44 mV	Measurement range not reached (input voltage < -10 V) Measurement range exceeded (input voltage >10 V) Wire break
Temperature measurement PT1000	0.1°C	Measurement range not reached (temperature < -200°C) Measurement range exceeded (temperature >850°C) Wire break
Resistance measurement 1 - 4,000 Ω	122,074 mΩ	Measurement range not reached (resistance <1 Ω) Measurement range exceeded (resistance >4,000 Ω) Wire break

Relationship between numerical value and input voltage:

Numerical value (INT)		Voltage measurement
Hexadecimal	Decimal	
8001	-32767	-10 V
C001	-16383	-5 V
FFF8	-8	- 2.44 mV
0000	0	0 V
0008	8	2.44 mV
3FFF	16383	5 V
7FFF	32767	10 V

3.7.5 Analog output

The analog outputs are written in INT16 format (16-bit 2s complement) beschrieben. You won't need to change anything here.

Relationship between numerical value and output voltage:

Numerical value (INT)		Output voltage
Hexadecimal	Decimal	
8001	-32767	-10 V
C001	-16383	-5 V
FFF0	-16	- 4.88 mV
0000	0	0 V
0010	16	4.88 mV
3FFF	16383	5 V
7FFF	32767	10 V

3.7.6 Counter settings

To set the correct counter modes, the configuration register must be written. Counter 1 and counter 2 registers have different meanings for different modes.

Incremental encoder operation

If the homing input (input 3) is *enabled* in the configuration register, then the Power Panel is a 32-bit ABR counter whose actual value is found in counter 1 and the saved R value in counter 2.

If the homing input is disabled, a 32-bit AB incremental encoder counter input is read in counter 1.

- A = digital input 1
- B = digital input 2
- R = digital input 3

Event counter operation

If the counters in the configuration register are initialized as event counters, two 32-bit counters are available.

- Counter 1 = digital input 1
- Counter 2 = digital input 2

Period measurement

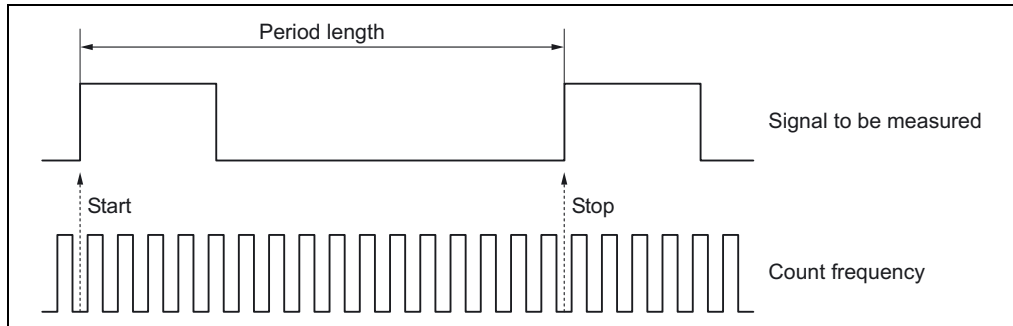

Figure 83: Power Panel 35-36 period measurement

The measurement can be begun at the decreasing or increasing edge depending on the configuration register. The counter frequency can be set in two steps (4 MHz or 31.25 kHz) or with an external frequency. The external frequency must however be less than 50 kHz. The measured counter state is a 32-bit value and is displayed in counter 1 or counter 2. The value in the temporary register is only updated at the end of the measurement.

The frequency of the signal to be measured can be a maximum of 50 kHz.

- Counter 1 = digital input 1
- Counter 2 = digital input 2
- Ext. Counting frequency = digital input 3

A potential overrun of the continuous counter during the period measurement (e.g. due to an incorrect counter frequency), can be detected by reading bit 9 (counter 1) or bit 10 (counter 10) in the status register. However, the maximum value of counter is limited to \$0000FFFF as a result. The error bit in the status register is acknowledged by resetting bit 9 (counter 1) or bit 10 (counter 2) of the configuration register.

Gate measurement

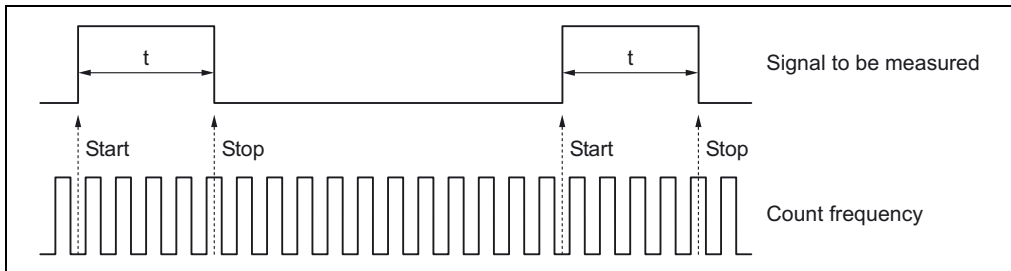

Figure 84: Power Panel 35-36 gate measurement

The measurement can be begin at the decreasing or increasing edge depending on the configuration register. The R enable bit must be 0. Measurement always occurs up to the next edge. The counter frequency can be set to one of two levels (4 MHz or 31.25 kHz) or with an external frequency. The external frequency must however be less than 50 kHz. The measured counter state is a 32-bit value and is displayed in counter 1 or counter 2. The value in the temporary register is only updated at the end of the active measurement.

The frequency of the signal to be measured can be a maximum of 50 kHz.

- Counter 1 = digital input 1
- Counter 2 = digital input 2
- Ext. Counting frequency = digital input 3

A potential overrun of the continuous counter during the gate measurement (e.g. due to an incorrect counter frequency), can be detected by reading bit 9 (counter 1) or bit 10 (counter 2) in the status register. However, the maximum value of counter is limited to \$0000FFFF as a result. The error bit in the status register is acknowledged by resetting bit 9 or bit 10 of the configuration register.

4. Supply voltage

3-pin terminal block	Terminal	Assignment
 <p>OTB103.91</p>	1	24 VDC
	2	Ground
	3	GND

Table 57: Power Panel 35 terminal assignments X3 / voltage supply

5. Interfaces

5.1 RS232 interface

This non-electrically isolated interface is primarily intended for programming the CPU. The RS232 can also be used as a general interface (e.g. printer, bar code reader, etc.).

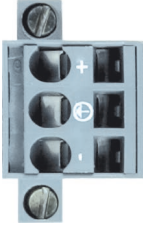
9-pin DSUB connector	Terminal	Assignment
 <p>9-pin DSUB plug</p>	1	n.c.
	2	RXD
	3	TXD
	4	n.c.
	5	GND
	6	n.c.
	7	RTS
	8	CTS
	9	n.c.

Table 58: Power Panel 35 pin assignments IF1 / RS232

5.2 CAN interface

The electrically isolated standard fieldbus interface is used for the following tasks:

- Communication with other control systems
- Decentralization and remote I/O expansion using B&R 2003 components and a CAN bus controller

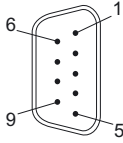
We recommend using the AC911 T-connector for connecting to a CAN network. A terminating resistance is integrated in the T-connector for the bus termination, which can be turned on or off. For more information on wiring CAN fieldbus systems, see chapter 2 "Installation", section "CAN Fieldbus", in the B&R SYSTEM 2003 User's Manual.

9-pin DSUB connector	Terminal	Assignment
 <p>9-pin DSUB plug</p>	1	n.c.
	2	CAN_L
	3	CAN_GND
	4	n.c.
	5	n.c.
	6	n.c.
	7	CAN_H
	8	n.c.
	9	n.c.

Table 59: Power Panel 35 pin assignments - IF2 / CAN

6. Operating mode and node number switch

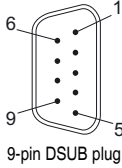
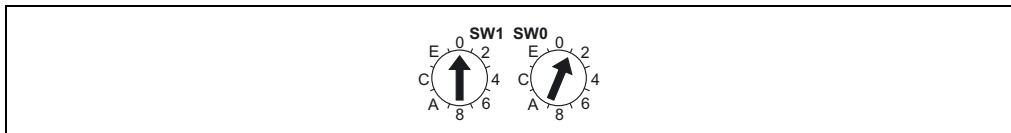

Figure 85: Power Panel 35 operating mode and node number switch

The Power Panel 35 is equipped with 2 hex switches, which are used as an operating mode switch. The switch positions 01 - FE are used to set the CAN node number. The operating system only interprets the switch position when switched on.

All other switch positions are reserved for special functions.

Switch position	Description
^	In this switch position, the operating system can be programmed via the online interface. User FlashPROM is only deleted after the update begins.
01 - FE	Freely available for use in an application (e.g. CAN node number)
FF	Diagnostics mode: The CPU boots in Diagnostics mode. Program sections in User RAM and User FlashPROM are not initialized. After diagnostics mode, the CPU always boots with a cold restart.

Table 60: Power Panel 35 switch positions of the operating mode and node number switch

7. Dimensions

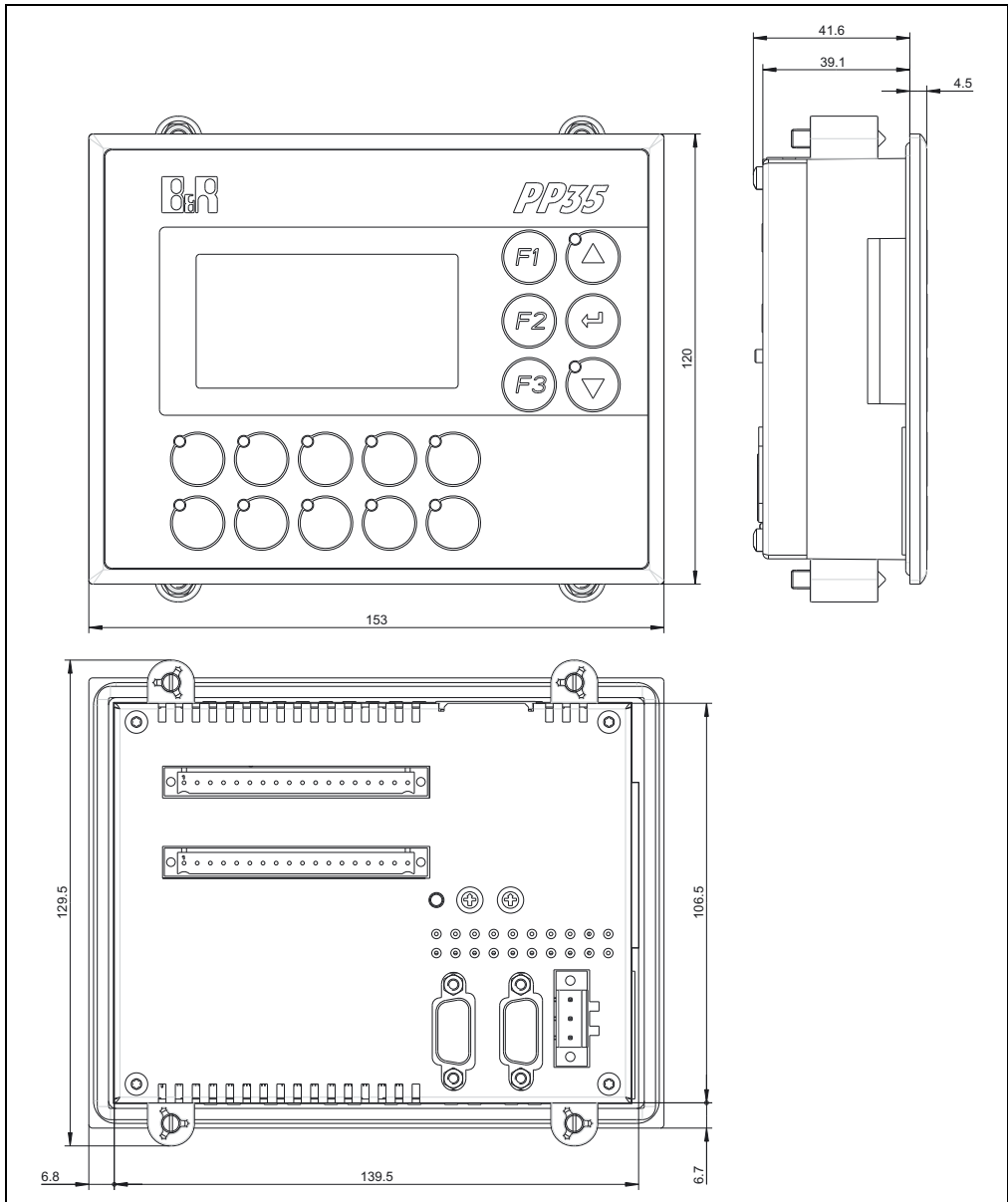

Figure 86: Power Panel 35 dimensions

Installation cutout: 141 mm x 108 mm (max. 4.5 mm plate thickness)

8. Set display contrast

The display contrast is set at the factory. However, the user can make a different contrast setting as desired. To do this, press "ENTER". While holding down this key, the "UP" and "DOWN" keys can be used to set the contrast:

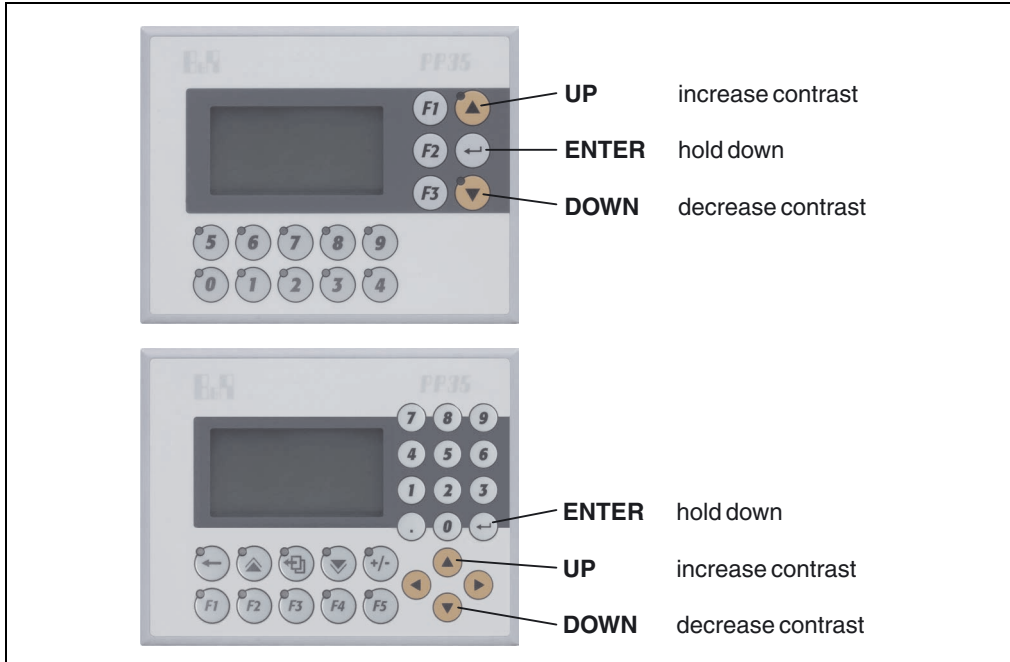

Figure 87: Power Panel 35 set display contrast

The contrast setting made in this way is placed in nonvolatile memory and is used from now on as the default value.

WARNING

The key codes for "UP" and "DOWN" are not sent to the controller as long as "ENTER" is being pressed. It is also not possible to use the key combinations ENTER + UP or ENTER + DOWN in the application project.

9. Note regarding operation

Caution!

Pressing several function or system keys at the same time may trigger unintended actions.

10. Changing the battery

10.1 Battery data

Lithium battery	3 V / 950 mAh
Model number	0AC201.9 (lithium batteries, 5 pcs.) 4A0006.00-000 (lithium battery, 1 pc.)
Storage time	Max. 3 years at 30° C
Humidity	0 to 95% (non-condensing)

Table 61: Power Panel 35 battery data

10.2 Buffer duration

Buffer current	Panel CPU
Typical	10 μ A
Maximum	200 μ A

Table 62: Power Panel 35 buffer duration

Information:

B&R recommends changing the batteries after five years of operation.

10.3 Steps for changing the battery

The product design allows the battery to be changed with the Power Panel switched on or off. In some countries, safety regulations do not allow batteries to be changed while the module is switched on.

Information:

Data stored in RAM will be lost if the battery is changed with the PLC switched off.

The battery is changed as follows:

- Touch the mounting rail or ground connection (not the power supply!) in order to discharge any electrostatic charge from your body.
- Remove the cover from the lithium battery holder using a screwdriver.
- Remove the battery from the holder by pulling the removal strip (don't use uninsulated tools -> risk of short circuiting).

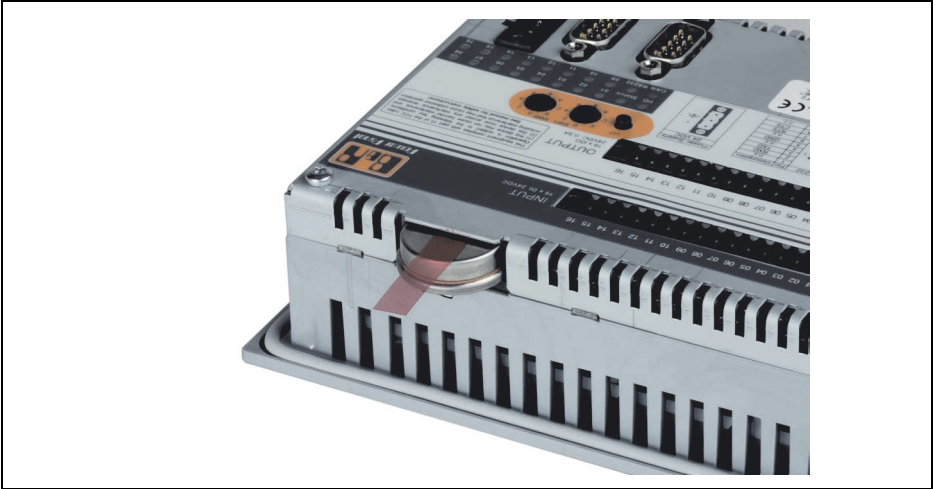

Figure 88: Power Panel 35 changing the battery

- The battery should not be held by its edges. **Insulated** tweezers may also be used for removing the battery.

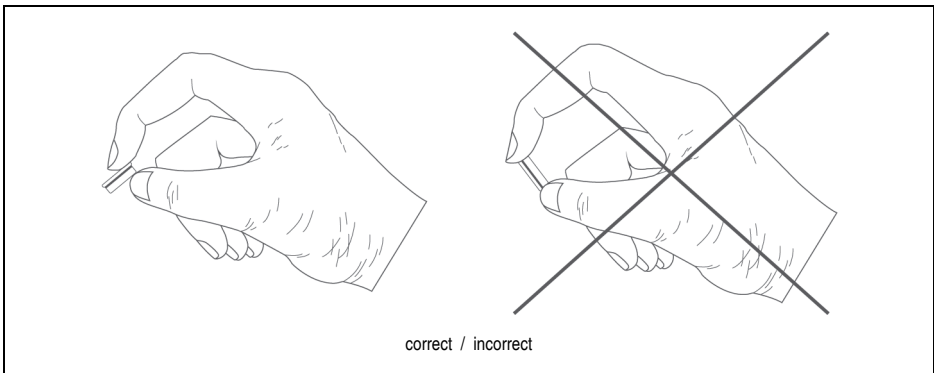

Figure 89: Power Panel 35 handling the battery

Power Panel 35 • Mounting instructions

- Insert the new battery with correct polarity. The removal strip should be protruding from the battery holder and the "+" side of the battery should be facing downward. In order to be able to remove the battery again in future, the removal strip **must** protrude from the upper side of the battery.
- Now wrap the end of the removal strip over the top of the battery and insert it underneath the battery so that it does not protrude from the battery holder.

Information:

Lithium batteries are considered hazardous waste. Used batteries should be disposed of accordingly.

11. Mounting instructions

The following mounting instructions should be noted:

- 1) The Power Panel 35 should be mounted with the four retaining clips (two left and two right), which are supplied in the delivery.
- 2) In order to guarantee proper air circulation, allow a distance of at least 20 mm (above and below) between the ventilation slots and all other objects.

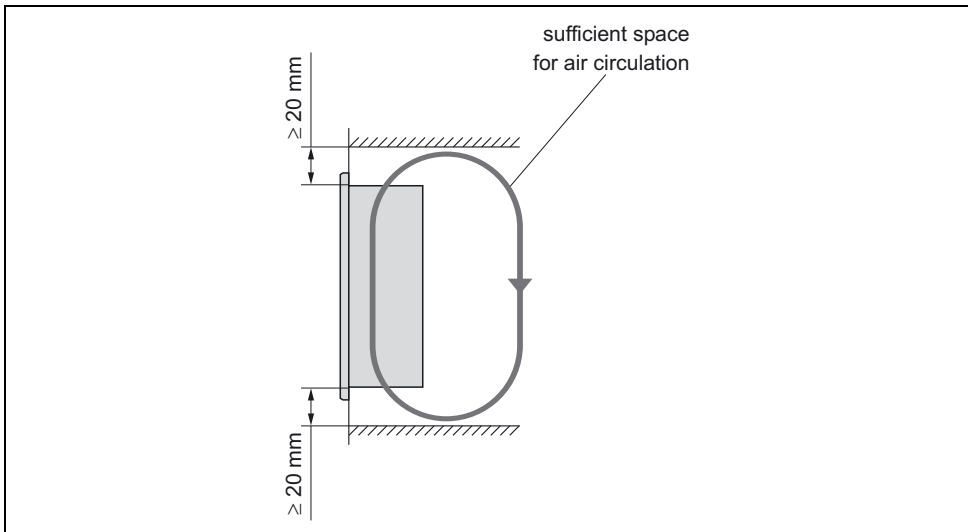

Figure 90: Power Panel 35 distance for air circulation